

# OPERATING INSTRUCTIONS

## 08.16 PIPETTE APPARATUS

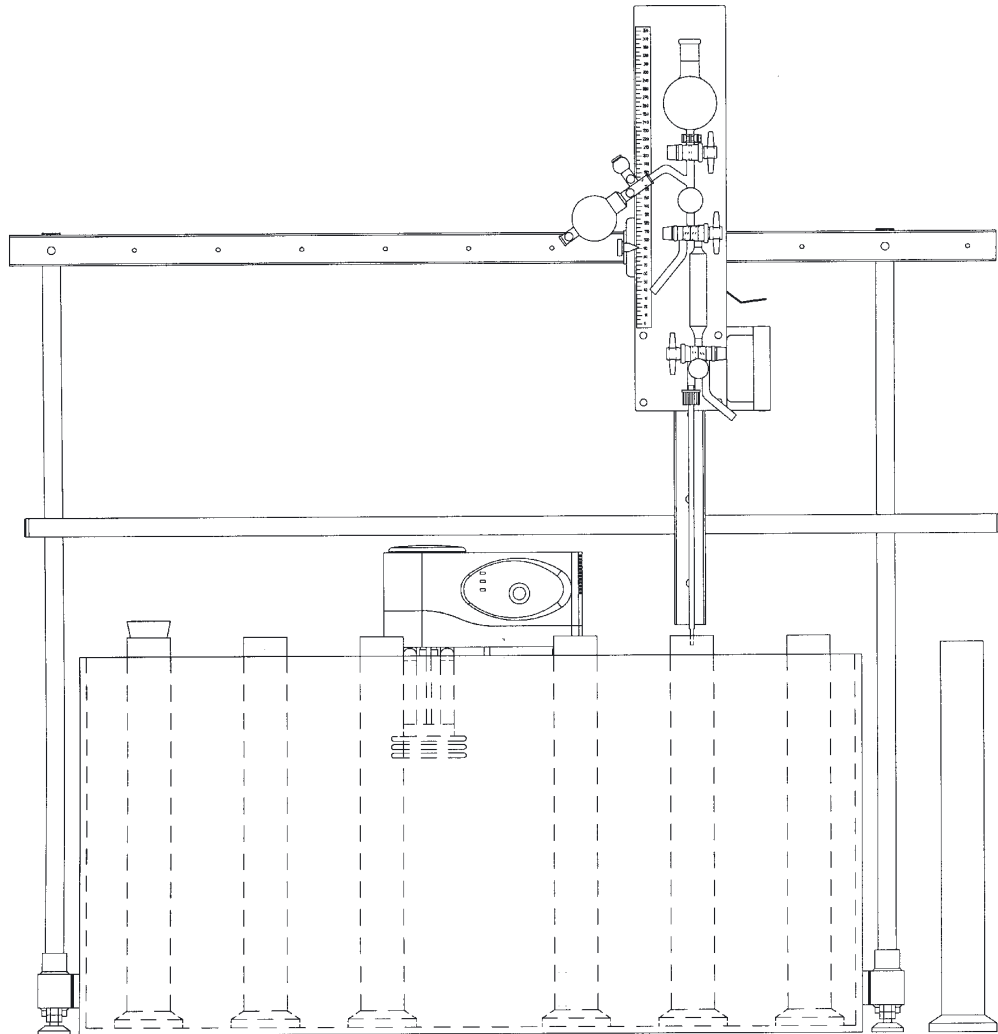

### Contents

On these operating instructions.....	2
1. Description of the apparatus .....	2
2. Principle .....	2
3. Introduction .....	3
3.1 Bench model .....	3
3.2 Heating element with thermostat and stirrer .....	5
4. Determination of the lutum content (fractions $<2 \mu\text{m}$ ) and/or the fraction of particles smaller than or equal to $35 \mu\text{m}$ .....	5
4.1 Determination of the in-feed depth of the pipette .....	5
4.2 Pipetting.....	6
4.3 Calculation of the lutum content and/or the fractions to particles smaller than or equal to $35 \mu\text{m}$ .....	7
4.4 Determination of the mass percentage of the total fraction to particles larger than $35 \mu\text{m}$ .....	7
Appendix 1: Flow diagram of the determination of the particle-size distribution .....	8

## On these operating instructions



If the text follows a mark (as shown on the left), this means that an important instruction follows.



If the text follows a mark (as shown on the left), this means that an important warning follows relating to danger to the user or damage to the apparatus.

### 1. Description of the apparatus

The pipette apparatus as described in these instructions meets the demands of the NEN 5753 'Determination of the grain-size distribution with the aid of sieve and pipette' and with the demands of the ISO/DIS 11277. The pipette apparatus consists of a frame with a runner with pipette holder fixed on top of it, an upper pipette, an under pipette, and a pipette balloon. The front plate of the runner is provided with a millimeter graduation. Depending on the model, a bench or wall frame is used. With one single apparatus it is possible to determine the grain-size distribution of 7 samples.

Furthermore, the pipette apparatus comes with:

- a glass tank (capacity: ca. 110 l)
- a heating element with thermostat and stirring device (including fastening materials)
- glass sample cylinders (1000 ml) provided with rubber stoppers.

Properties

- The maximum in-feed depth of the pipette is 340 mm.
- The total length of the frame is 103.5 cm. The capacity of the glass tank is ca. 110 liter.
- The apparatus is available as bench model (art. nr: 08.16.SA).

### 2. Principle

The particle-size distribution is one of the most important physical characteristics of a soil. Soil classification is mainly based on the particle-size distribution. Many properties of the soil are related to the particle-size distribution, such as 'heaviness', processability, swelling capacity and shrinking capacity, moisture characteristic, permeability, adsorption capacity, etc. With the help of a pipette apparatus, the particle-size distribution (and the lutum content (0-2  $\mu\text{m}$ )) is determined for the fractions to particles smaller than or equal to 35  $\mu\text{m}$ . The samples must be pre-treated in accordance with the NEN 5751 (ISO 11464, DIN 19683) norm, after which organic materials, carbonates, and, possibly, iron oxides are removed. After removing these, the sample is sifted and divided into two fractions. The sample with a sodium pyrophosphate solution (a peptising agent) is filled up to 1000 ml with water and poured into the cylinder in suspension. Other peptising agents, such as hexametaphosphate, possibly in combination with soda and similar agents, are allowed by the norm, provided that similar results are obtained. The graduated measuring cylinder must be placed in the glass tank. The glass tank is filled with water of a temperature that is kept at as constant a level as possible with the aid of the heating element with thermostat and stirring element (art. nr: 08.30.10). The cylinder must be in a vibration-free position.

The pipetting method is based on the difference in sedimentation velocity between large and small soil particles.

The sedimentation of the particles is the result of two opposite forces, namely gravity and friction as a result of movement in a liquid medium. In the pipetting method, a sample is pipetted of a suspension of the sample in a graduated measuring cylinder at various times and depths. Times and depths are determined with Stokes' law. The pipetted suspension is evaporated down and dehydrated, and the mass percentage of the pipetted fraction is determined by weighing.

### 3. Introduction

Every pipette apparatus that comes out of our plant is subjected to a very strict final inspection. Upon receiving the apparatus, please check first whether the apparatus itself or any components have suffered damage during transport. With the help of the enclosed set specification sheet, please ascertain that nothing is missing.



**Please read these instructions before using the pipette apparatus.  
Keep the instructions in a place that is accessible for every user.**

#### 3.1 Bench model

Place the underframe (2) of the bench frame on a solid table or bench (the rubber anti-vibration plates facing you). Below, you will find a description of how the apparatus is to be installed after you have dismantled it for transport. Fix the guide rail for the runner in the holders using 2 screws, 4 washers and 2 screw nuts.

Fasten the guide tube (7) on the front of the both standards using two bolts. Place a plastic ring (hollow on one side) both at the front and at the back of the standard (at the front with the hollow side facing the standard; at the back with the hollow side facing the guide tube). Press the bolt through the hole. Now, fasten the nut to the bolt inside the guide tube. Place the plastic sealing caps in both ends of the guide tube. Now, fasten the two short standards on the underframe with two bolts. Fasten the two mounting strips (see also figure 3) on the heating element (15). With the inner socket head screws the heating element is now mounted on the two standards (see figure 4: Installation heating element).

Fasten the upper pipette (11) to the runner (10) by gently pressing the neck under the upper ball into the clamp (12) and gently fasten the screw. At the bottom, fasten the upper pipette using the plastic knurled nut (8) and a plastic ring. Secure the pipette balloon (13) to the upper pipette. Now, place the glass tank on the table, in such a way that the heating element is suspended freely in the tank. Secure the lower pipette (14) (see figure 2:

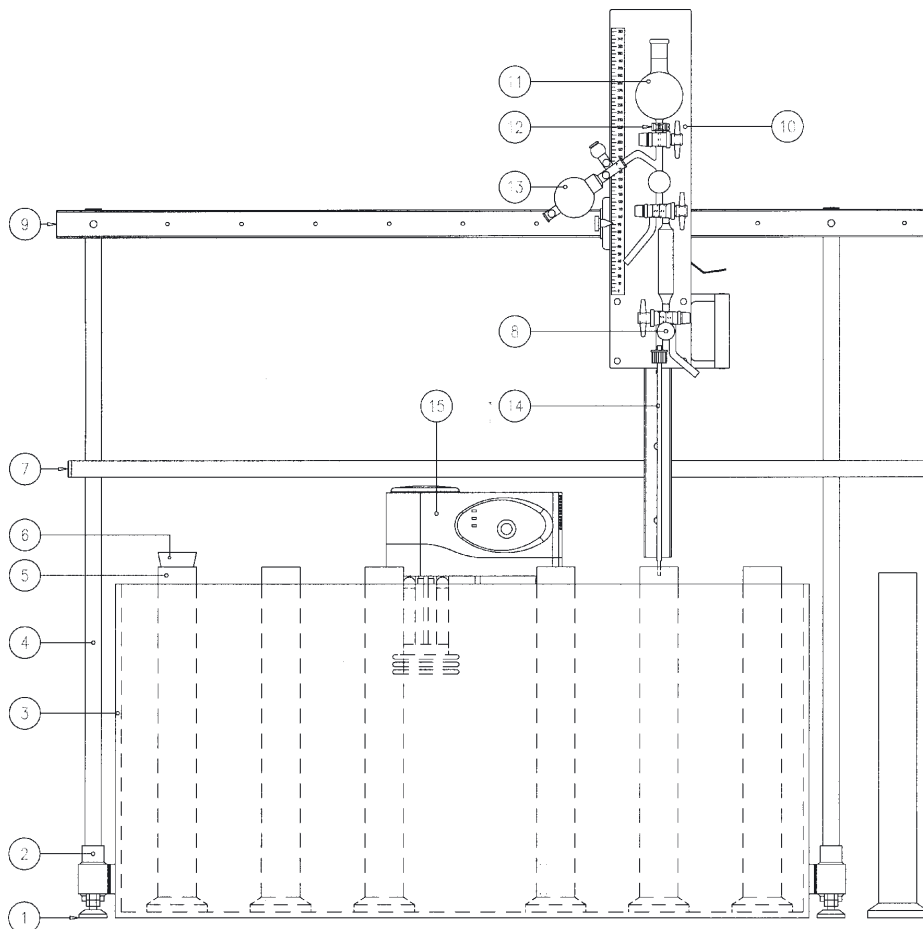

Figure 1 Pipette apparatus bench model

Installation upper pipette to the runner and lower pipette on upper pipette) only after you have placed the sample cylinders (5) in the glass tank. Use the jack screws (1) and a level to level the unit (see figure 1: Pipette apparatus, bench model). Be sure that the lower pipette can move freely above the sample cylinders.

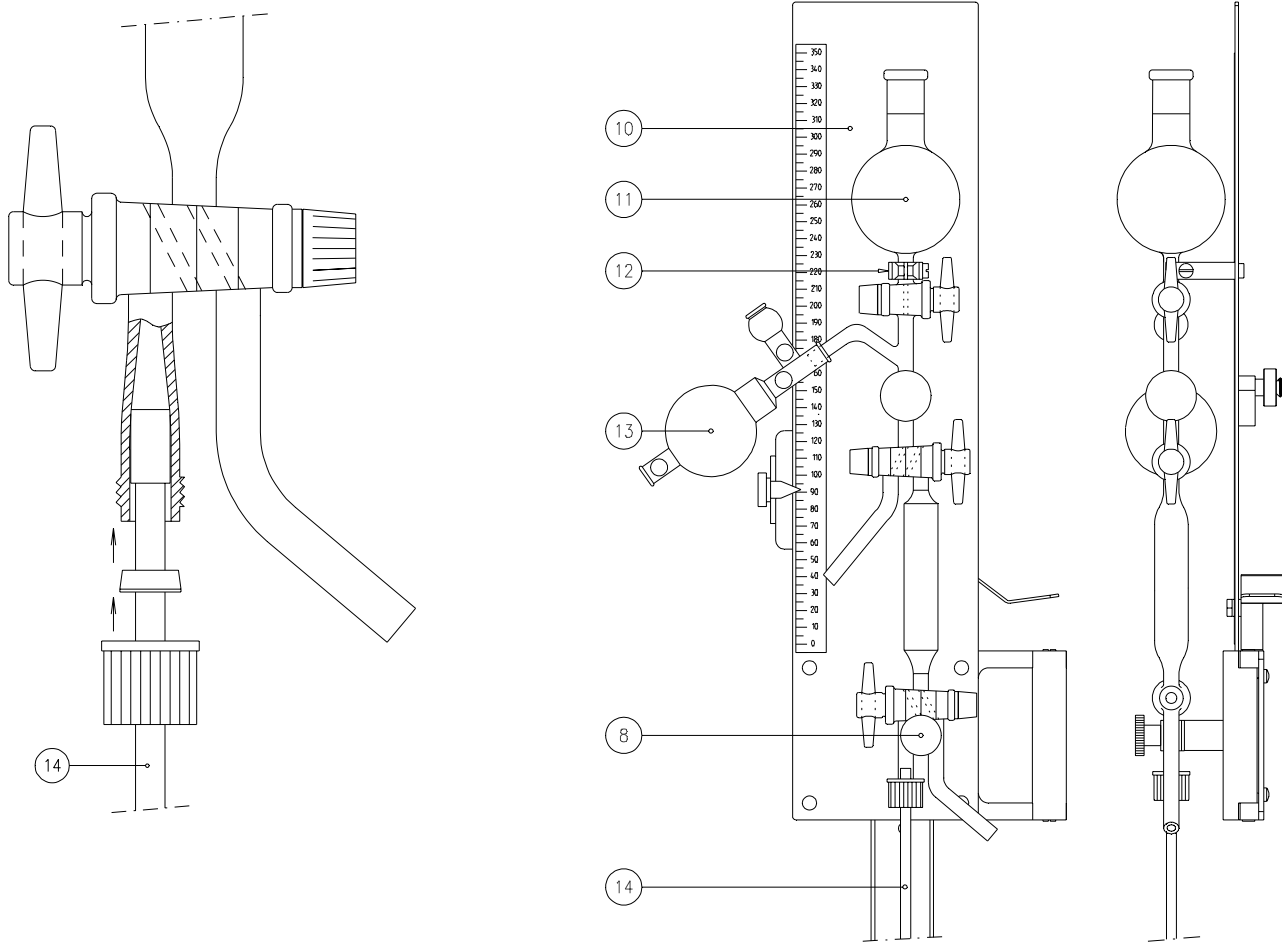

Figure 2 Installation upper pipette to the runner and lower pipette on upper pipette

### 3.2 Heating element with thermostat and stirrer

The heating element provides precise and safe heating, circulation and temperature control of the water in the glass tank. When used correctly, the constant temperature which the pipetting method requires is guaranteed. The adjusting knob on top of the apparatus enables you to set the temperature to the desired level. Using the knob at the side of the adjusting knob, you can fix the temperature setting. The mounting bracket must be removed before use in this set. (See figure for installation). The optional angle iron can be used to mount the heating element on a wall. For more extensive information on the heating element: please refer to the separately enclosed operating instructions of the heating element (08.30.10).

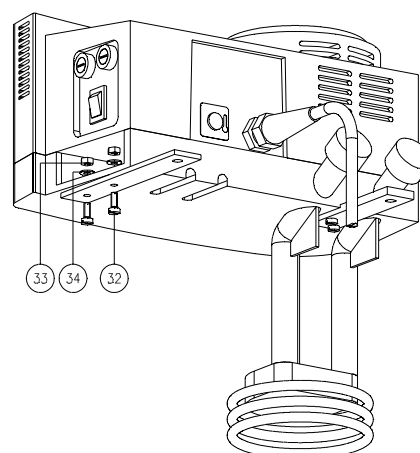

Figure 3 Installation of heating element

## 4. Determination of the lutum content (fractions <2 μm) and/or the fraction of particles smaller than or equal to 35 μm

After preparing the sample, in accordance with the norms (NEN 5751, ISO 11464, DIN 19683), a peptising agent is added to the suspension in the graduated measuring cylinder. The contents of the cylinder are left to cool down, and when this is done, water is added until the cylinder contains 1000 ml. The suspension is mixed (using a soil stirring device) and the measuring cylinder is placed in the glass tank which is filled with water and which is placed on a vibration-free table. The heating/stirring element provides the required constant temperature. Leave this to settle for 12 hours. The peptisation must be complete, since otherwise particles could inter-aggregate. One indication of incomplete peptisation is the forming of stratification of the suspension in the measuring cylinder. Also prepare one blank by filling a graduated measuring cylinder with 50 ml sodium pyrophosphate, adding water until it reads 1000 ml, and homogenizing this.

### 4.1 Determination of the in-feed depth of the pipette of the pipette

Determine the temperature of the blank and read the in-feed depth of the pipette and the sedimentation time of the desired fraction from the table below.

Mix the suspension intensively for at least 1 minute and start the chronometer. Pipette, after the prescribed sedimentation time, the particles smaller than or equal to 2 μm to determine the lutum content (lower the pipette slowly to avoid disturbance). To determine the particle-size distribution, first pipette the fraction smaller than or equal to 35 μm, and subsequently the other desired fractions in descending order according to particle size.

Temperature of the suspension °C	In-feed depth of the pipette in cm at	
	Upper limit particle fraction in μm	
	35	2
	After a sedimentation time of	
	90 sec.	4 hours
15,0	8,4	4,4
15,5	8,6	4,5
16,0	8,7	4,5
16,5	8,8	4,6
17,0	8,9	4,6
17,5	9,0	4,7
18,0	9,1	4,8
18,5	9,2	4,8
19,0	9,3	4,9
19,5	9,5	5,0
20,0	9,6	5,0
20,5	9,7	5,1
21,0	9,8	5,1
21,5	9,9	5,2
22,0	10,1	5,3
22,5	10,2	5,3
23,0	10,3	5,4
23,5	10,4	5,4
24,0	10,6	5,5
24,5	10,7	5,6
25,0	10,8	5,6

## 4.2 Pipetting

The norm speaks of a calibrated pipette with a capacity of around 20 ml. Our pipette has a capacity of 20 ml +/- 10%. This is the volume between the cocks.



**It is important that you determine the exact capacity of your pipette yourself, using a calibrated measuring jug. Later, you can use this value in the formula.**

- Make sure that the two-way cock (K1) and the cock K3 of the pipette are closed, and the two-way cock K2 of the pipette (P) is opened toward the pipette before you place the pipette (see sketch Pipette) over the measuring cylinder with the suspension, 30 seconds before pipetting.
- Insert the pipette into the suspension at the required depth (lower the pipette slowly to avoid disturbance).
- Connect exhaust point A to the pipette balloon.
- Open the two-way cock K1 and steadily draw the pipette full until the liquid level is above two-way cock K2.
- Close the two-way cocks K1 and K2.
- Lift the pipette out of the suspension and the measuring cylinder.
- Move the runner to the right (outside the glass tank).
- Open two-way cock K2 above drain D to drain off any excess suspension.
- Rinse overflow ball F with water from storage ball W by opening cock K3.
- Open the two-way cock K2 above pipette P.
- Open two-way cock K1 above drain E and empty the pipette in an evaporating dish. Rinse the pipette P with water from the storage ball W. Collect also this scouring water in the same evaporating dish.
- Open two-way cock K1 above pipette point S and remove the pipette from the suspension.

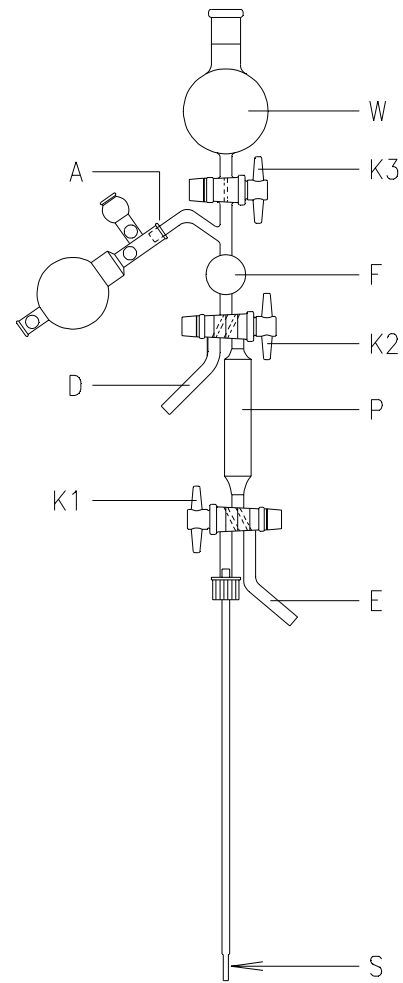

Figure 4 Upper and lower pipette

The evaporating dishes with the suspension are then dried and weighed. Subsequently, the blank is pipetted in quintuplicate and the content of the pipette is put into evaporating dishes that were dried and weighed before. These, too, are dried and the residue after evaporation is weighed accurately. Of these results, the average is taken.

### 4.3 Calculation of the lutum content and/or the fractions to particles smaller than or equal to 35 µm

The mass percentage of the fractions which are to be distinguished is determined using the following formula:

$$W_i = \frac{(m_2 - m_1 - \overline{m_b}) \times V_1}{V_2 \times m \times ds} \times 100\%$$

in which:

$W_i$  = the mass percentage of the fraction  $i$ , in % (m/m) of oven dried soil

$m_2$  = the mass of the evaporating dish with the dried fraction in g

$m_1$  = the mass of the empty evaporating dish

$m_b$  = the average mass of the residue after evaporation of the blanks in g

$V_1$  = the volume of the suspension in the graduated measuring cylinder, in ml. (1000 ml.)

$V_2$  = the volume of the pipette (please refer to the first part of 4.2)

$m$  = the mass of the processed quantity of soil in g

$ds$  = the content of dry material of the processed soil in kg/kg

### 4.4 Determination of the mass percentage of the total fraction to particles larger than 35 µm

The mass percentage of the fraction is calculated according to the following formula:

in which:

$w$  = the mass percentage of the fraction to particles larger than 35 µm, in % (m/m) of oven dried soil

$$W = \frac{m_4 - m_3}{m \times ds} \times 100\%$$

$m_4$  = the mass of the evaporating dish with the dried fraction in g

$m_3$  = the mass of the empty evaporating dish in g

$m$  = the mass of the processed quantity of soil in g

$ds$  = the content of dry material of the processed soil in kg/kg

For more extensive information, we refer to the norm: NEN 5753 Soil. Determination of lutum content and particle size of soil samples with the aid of sieve and pipette. Including appendixes (ISO/DIS 11277, DIN 66115).

Nothing in this publication may be reproduced and/or made public by means of print, photocopy, microfilm or any other means without previous written permission from Eijkelkamp Agrisearch Equipment.

Technical data can be amended without prior notification.

Eijkelkamp Agrisearch Equipment is interested in your reactions and remarks about its products and operating instructions.

# Appendix 1: Flow diagram of the determination of the particle-size distribution

