

OPERATING INSTRUCTIONS

08.01 SANDBOX



Contents

1 Introduction.....	2
2 Description of the Sandbox	2
3 Technical Specifications.....	2
4 Assembling the Sandbox.....	4
4.1 Before Setting up the Sandbox	4
4.2 Setting up the Sandbox	6
5 Using the Sandbox.....	11
6 Table to be filled in as measurements are taken.....	15
7 Trouble-shooting	16
8 Maintenance of Suction Table	17
Appendices.....	18
References.....	25

1 Introduction

This 08.01 Sandbox can be used to apply a range of pressures from pF 0 (saturation) to pF 2.0 (-100 hPa). Sand is used to convey the suction from the drainage system to the soil samples. The surface of the sand is flexible, which makes it easier to restore the contact between it, and the samples, after they have been removed for weighing. This quality makes sand a better suction material than a stiff porous plate, for this instrument.

If the influence of higher pF-values needs to be measured, then additional equipment is required. The 08.02 Sand/Kaolin box can be used to determine moisture percentages at pF-values from 2.0 (-100hPa) to 2.7 (-500 hPa), while 08.03 Pressure Membrane Apparatus can create pressures from pF 3.0 to pF 4.2. A pF-value of 4.2 is equal to -15,000 hPa of pressure, which is often taken as the lower limit of soil-moisture availability to plants.

Results of measurements taken with this sandbox correspond with points on the drying curves of the relevant samples; associated with *decreasing* pressure. These pressure values are usually standard water potential increments. The wetting curve, on the other hand, is determined by graphing the water content against *increasing* pressure values. This curve is not identical to the drying curve, because the water content does not respond instantaneously to changes in pressure (Hysteresis).

2 Description of the sandbox

The assembled sandbox can be seen in Figure 1. In the bottom of the box (1) is a PVC-pipe drainage system (4). This box is filled with fine synthetic sand, which is covered with a nylon filter cloth. The assemblage stage (Chapter 4) is only necessary prior to the initial use of the sandbox: After which, with proper maintenance (Chapter 9), the sandbox can be used for several years. Soil sample core rings are placed on top of the filter cloth to take measurements.

 **If the sandbox has already been assembled then begin at Chapter 5.**

The '*Hanging Water Principle*' is used to apply suction to the soil samples. The difference in height between the Suction Regulator (11) and the middle of the soil samples determines the amount of pressure. Pressure heads (h) between 0 and - 100 cm can be applied. The Suction Regulator (11) is adjusted to apply specific pressures to the soil samples. The samples are weighed after they have reached equilibrium at a specific pressure. Finally, the samples are dried and weighed so that the water content at each specific pressure can be deduced.

3 Technical specifications

Item	Specification
Soil sample rings (Ø 53mm)	Max. 40
Dimensions of the box on its stand (excl. supply bottle etc.)	55.0 x 33.5 x 37.5 cm (l x w x h)
Operating range	(0 hPa - 100 hPa) ; (0 bar - 0.1 bar) ; (pF 0 – pF 2.0)

Figure 1: Assembled Sandbox with numbered components

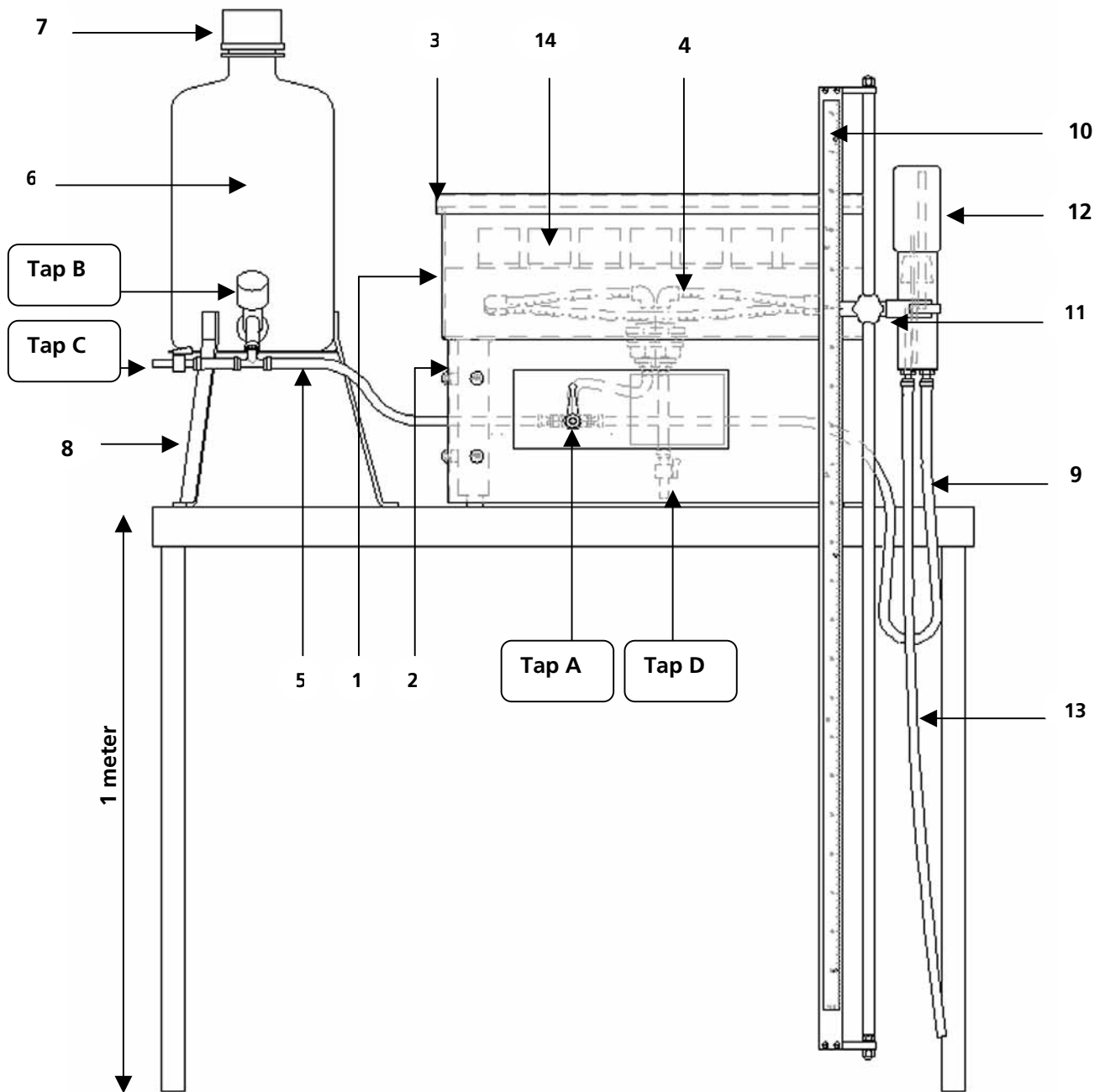

- | | | | |
|---|---------------|-----|-------------------------|
| 1 | Box | 9. | Discharge pipe |
| 2 | Box frame | 10. | Sliding measuring stand |
| 3 | Box lid | 11. | Suction regulator |
| 4 | Drainage pipe | 12. | Evaporation Reservoir |
| 5 | Supply pipe | 13. | Outflow pipe |
| 6 | Supply bottle | 14. | Sample |
| 7 | Bottle lid | | |
| 8 | Bottle stand | | |

4 Assembling the sandbox

👉 **If the sandbox is already assembled then skip to Chapter 5.**

All of the tubes are connected and tested for leakage before delivery.

👉 **Take care not to break the tube connections while unpacking.**

Construct the sandbox using the following instructions (Numbers refer to Figure 1):

4.1 Before setting up the sandbox:

Before the sandbox is assembled, the plastic drainage pipe (4) inside the box (1) must be covered with filter cloth. The supplied filter cloth has two layers, and is 6cm wide. The plastic drainage pipe needs to be covered by 3 layers of cloth to disperse the suction, and to stop sand from blocking the pipe's holes when this suction is applied.

To apply the filter cloth to the pipe, the following steps should be followed:



Figure 2: Cut 3.5 m down one side.

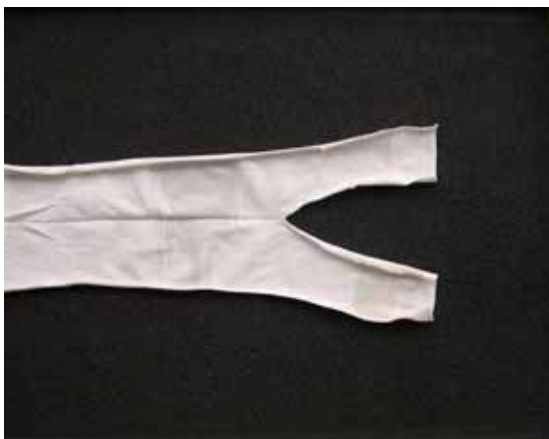

Figure 3: The 10 cm long 'ties'

4.11. Cut a 3.5 m long section from the supplied roll of filter cloth.

4.12. Cut down one side the filter cloth to make a single 12cm wide layer. (Fig. 2).

4.13. To knot the cloth to the pipe, a 10cm long section is cut into the each end of the strip to form two ties. (Fig. 3)

4.14. Saturate the filter cloth in demineralised water. (Fig. 4).

4.15. Tie the filter cloth to one end of the drainage pipe - where it enters the inside of the box.

4.16. Coil the filter cloth around the drainage pipe so that each consecutive winding covers two thirds of the width of the previous one. This will ensure that the entire pipe is covered by three layers of filter cloth. (Fig. 5).



Figure 4: Saturate Cloth

- 4.17. Fasten the cloth at the other end of the pipe.
- 4.18. Cut off the extra cloth, and tie the end to one end of the drainage pipe.

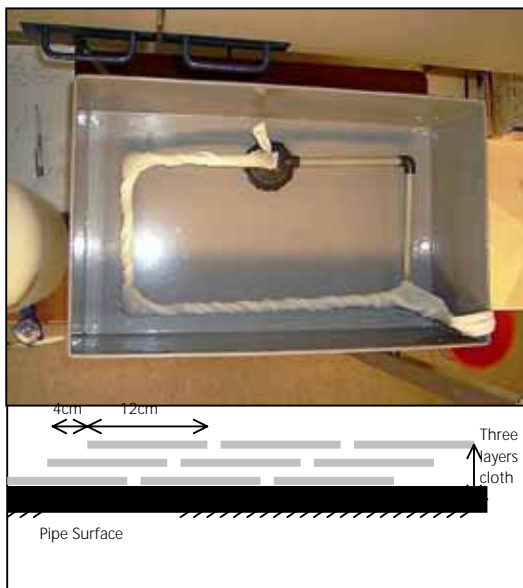

Figure 5: Filter cloth winding



Figure 6: Complete Cloth Covering

Setting up the sandbox:



Figure 7: Tap A 'closed'



Figure 8: Fix sliding measuring stand



Figure 9: Outflow from Suction Regulator

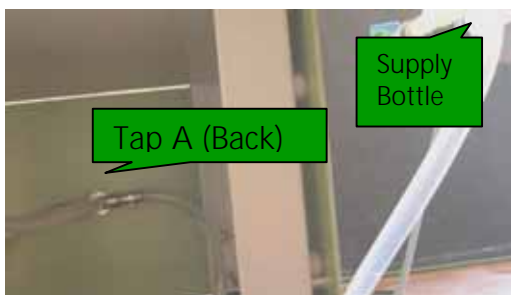

Figure 10: Supply Bottle attached to Tap A

☞ **The water level in the supply bottle should not be higher than the top of the box, because it may cause the water to flow too quickly (7500ml).**



Figure 11: Turn Tap B 'On'.

4.21. Select a completely level, vibration free table that is at least 1.0 m tall.

☞ **Vibration may cause a leak between the sidewalls of the box and the sand.**

4.22. Place the sandbox on this table, with Tap A facing the front and turned to the 'Closed' position. (Fig. 7).

4.23. Fix the sliding measuring stand (10) with suction regulator (11) and evaporation reservoir (12) to the box (1), using the two bolts provided. (Fig.8).

4.24. Allow the outflow pipe (13) from the suction regulator (11) to hang from the table into a bucket. (Fig. 9).

4.25. Boil 8L of demineralized water, and fill the supply bottle (6) with it once it has been left to cool. (May add Copper Sulphate to reduce algae/bacterial activity).

4.26. Place the supply bottle (6) on its stand (8) to the left of the box. The stand elevates the base of the bottle to the same height as the base of the box (1).

4.27. Connect the supply bottle (6) to Tap A with the supply pipe from the back of the box. Leave Tap A 'Closed'. (Fig.10).

☞ **You may add (0.01 mg/l) copper sulphate to reduce microbiological activity**

4.28. Air bubbles should now be removed from the piping in the system. Begin by opening the lid of the supply bottle (6), and turning the supply Tap B on. (Fig.11).



Figure 12: Half-fill box with water

4.29. Turn Tap A, on the front of the box, to 'Supply', and allow water to flow from the supply bottle (6) into the box (1) until the box is half-full with water. (Fig. 12)

4.210. Turn Tap to the 'Closed' position.

☞ The water level in the supply bottle (1) should never fall below the plastic drainage pipe inside the box (4500ml). Turn Tap A to 'Closed' when refilling the supply bottle. Let the water settle in the supply bottle before returning Tap A to 'Supply'. Tap gently on the tubes as water is flowing to help bubbles escape.



Figure 13: Air-bubbles released through Tap D

4.211. Open Tap D, at the back of the box (green) and allow some water to flow from the box (1) into a beaker. (Fig 13).

☞ The water level in the box (1) should never fall below the plastic drainage pipe.

4.212. When there are no bubbles left between Tap B and Tap D, close Tap D while leaving Tap B open.

4.213. Turn Tap A to the 'Closed' position. There should now be no bubbles between Tap B and Tap A, and between Tap A and the drainage pipe.

4.214. Fill the regulator bottle of the evaporation reservoir (12) with demineralised water, and put the plug back in before replacing the bottle. (Fig.14).



Figure 14: Evaporation reservoir

4.215. Set the suction regulator (11) to its lowest position (max. suction) near the bucket. (Fig. 15).

4.216. Turn Tap A to 'Discharge', and allow water to flow from the box (1) through the suction regulator (11) into a bucket until there are no bubbles between Tap A and the suction regulator. (Fig. 15). In general: if you place the tap in the discharge position, there must be a water flow from the sand box towards the suction regulator (this is the position for measurements). If the tap is placed in the supply position there is a waterflow from the supply bottle towards the sandbox. Important is to have the water level in the supply bottle always higher than the sand level in the box.



Figure 15: Suction Regulator at max.

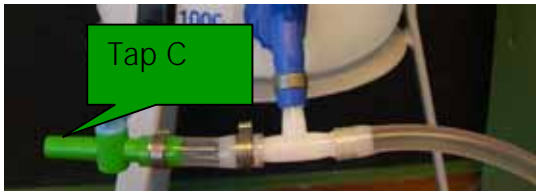

Figure 16: Let some water out of Tap C.

4.217. Turn Tap A to the 'Closed' position.

4.218. Leave Tap B on so that water runs out of Tap C when you open it. Let some water out of Tap C to remove the final air bubbles. (Fig.16).

☞ There must be no air-bubbles in the system from this point onwards.



Figure 17: Saturate sand with water

4.219. Saturate some synthetic sand with running demineralised water and stir firmly to remove air. (Fig 17). There should be a high ratio of water to sand (Fig. 18) so that it can be easily poured into the box (1). For the textural composition of the sand see Table 1.

Table 1: Textural Composition of Synthetic Sand

Particle diameter (μm)	Percentage occurrence
106	0
75	6.3
63	61.4
53	22.1
45	4.4
<45	5.8



Figure 18: A high ratio of water to sand

4.220. Slowly pour the water-saturated sand into the water in the sandbox (Fig 19) while the water is constantly stirred to expel any entrapped air. Alternatively, the sand may be added with a ladle.



Figure 19: Adding water-saturated sand

☞ Be careful to avoid damaging the drain system while stirring.

4.221. The sand should be pressed against the side walls of the sandbox, and into the corners, to make sure that the sand does not contain air pockets and a good seal between sand and box is established. (Fig. 20).



Figure 20: Achieve a good seal.

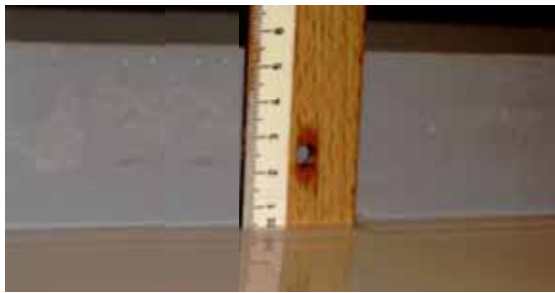

Figure 21: Retain 0.5 cm water above the sand

4.222. When the water level in the box becomes too high, then turn Tap A to 'Discharge'. Allow the excess water to flow out into a bucket. Always retain a layer of water above the sand and drainage system. (Fig. 21).

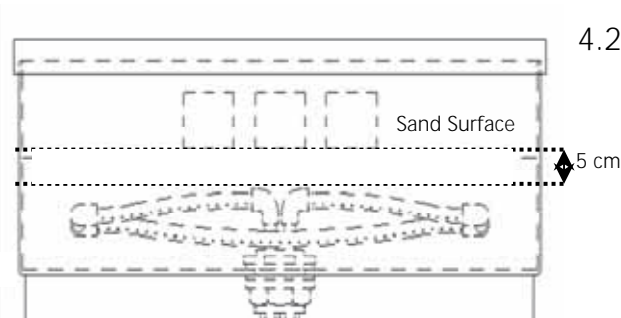

Figure 22: Depth of sand

4.223. Stop adding the saturated sand when the sand level is about 5cm above the highest point of the plastic drainage pipe, or about 6.5cm below the rim of the box (1) (Fig. 22).

☞ **There must be at least 6cm of space between the sand and the top of the box to place the soil sample rings under the lid.**

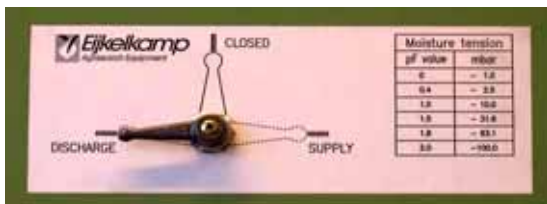

Figure 23: Tap A 'Discharge'.

4.224. Excess water can now be drained – leaving 0.5cm of water above the surface level of the sand. Put the suction regulator at its lowest point, and turn Tap A to 'Discharge' (Fig. 23).

☞ **The sand level must always remain 0.5cm under water, otherwise air will be sucked into the sand.**



Figure 24: Smooth sand with a clean ruler

4.225. Smoothen the surface of the sand, and leave it to settle. (Fig. 24).

4.226. Turn Tap A to the 'Supply' position, and open Tap B. Water from the supply bottle will now flow through the drain and remove final air residues. Each time air appears to be entrapped, the above described procedure is repeated to remove it. (Fig. 25).

☞ **The supply bottle cap must be open.**

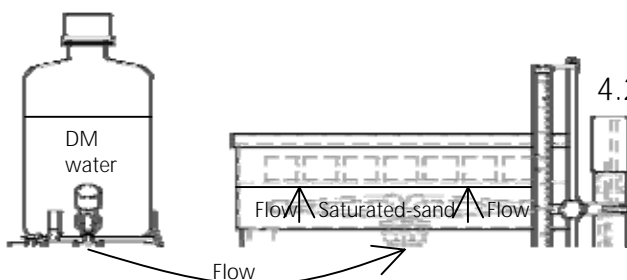

Figure 25: Remove final air residues

4.227. Once the surface layer of the sand is completely covered with a 1cm layer of water, all taps must be closed.



Figure 26: Disperse bubbles under the cloth

- 4.228. Cover the surface area of the sand with a piece of fully saturated protection cloth.
- 4.229. Disperse any air bubbles between the protection cloth and the sand by gently smoothing from the centre outwards. (Fig. 26).
- 4.230. The middle of the soil sample is used as the reference level for zero pressure. Use the omega ruler (Fig. 27) to set the zero point on the sliding ruler to the correct height.

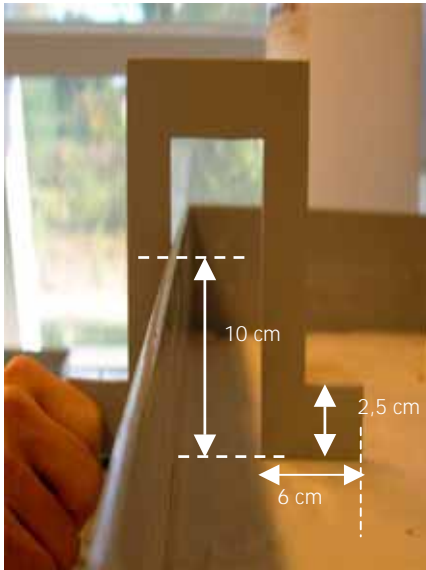

Figure 27: Side-view of the Omega Ruler

- 4.231. Gently loosen the small screws at the back of the sliding measuring stand to allow the ruler to be adjusted.
- 4.232. If you are using the standard 5 cm deep sample rings then the upper edge of one horizontal arm of the Omega ruler indicates the Zero point (Fig. 28) when the lower edge of the other horizontal arm is flat on the surface of the sand. (Fig. 27)
- 4.233. If you are using sample rings with a different depth then the Zero point is half the depth of that sample ring above the lower edge of the horizontal arm of the Omega ruler (Sand Surface).

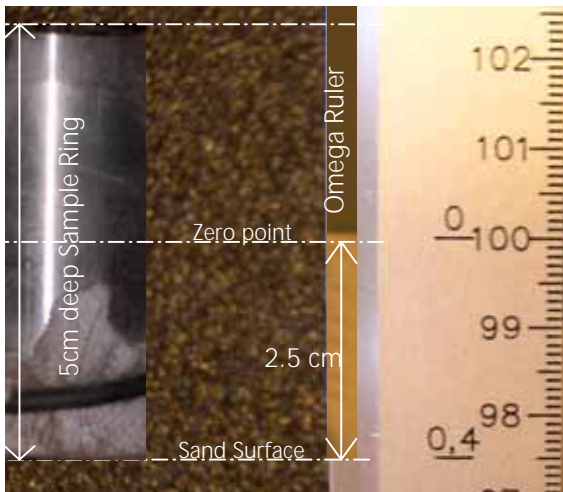

Figure 28: End-on view of Omega Ruler

👉 The 08.01 Sandbox is now ready to use. For instructions on how to use the andbox please see Chapter 5.

5 Using the Sandbox

The Laboratory should have a constant temperature between measurements, since temperature changes affect water viscosity and therefore water retention values.



Figure 29: Chip off excess soil – don't smear!



Figure 30: Cloth and O-ring on sample.

- 5.1. See Appendix 4 for how to take a proper soil sample.
- 5.2. Uncap the core sample ring. If the sampled soil volume is larger than the volume of the core ring, carefully remove excess soil by 'chipping' it off with a sharp edged tool. Prevent smearing the sample surface so as not to affect the physical properties of the soil. (Fig. 29).
- 5.3. Fix a piece of nylon cloth to the bottom side (sharp edged) of the sample with an elastic-band, or an O-ring. (Fig. 30).

 **If the soil volume is less than the volume of the ring, or if the sample has been damaged during transport, the sample should not be used for analysis. Also samples with large projecting stones may have to be discarded.**



Figure 31: Retain 0.5cm water above sand

- 5.4 Ensure that a 0.5cm layer of water is covering the surface of the sand in the sandbox. (Fig. 31).
- 5.5 Place the soil sample with the bottom side down in the sandbox. Let the sample adapt for 1 hour. (Fig. 32).
- 5.6 To saturate the sample, Turn Tap A to '*Supply*' and slowly raise the water level to 1 cm below the top of the sample ring.



Figure 32: Allow samples to adapt for 1hr.

 **Fast raising of the water level will entrap air and may damage soil structure. (Fig. 33).**



Figure 33: Saturate Sample (Water 1cm below top)

- 5.7 Turn Tap A to the '*Closed*' position when the water level is 1cm below the top of the sample rings. (Fig. 33).
- 5.8 Place a lid on the basin (to prevent evaporation) and allow the sample to saturate for 2 or 3 days (sandy soils) or up to 1 or 2 weeks (clayey soils).



Take care not to leave sandy soils wetting for too long since slaking may occur.



Figure 34: Mark samples

5.9 Mark the rings, and draw a diagram of the box, so that the rings can be replaced in exactly the same place after removal. (Fig. 34).

5.10 Take the ring carefully out of the water basin and wipe off any water drops hanging underneath the sample before weighing it. (Accuracy of balance 0.01g). This weight (including ring, cloth and elastic) is used to calculate water content at saturation, pF 0 (weight A, See Chapter 6). (Fig. 35).

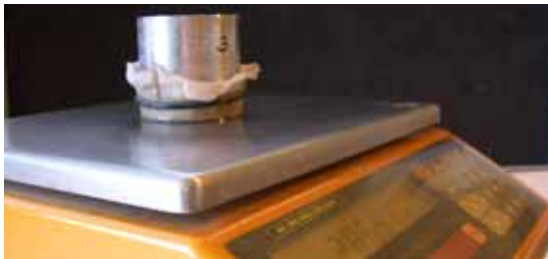

Figure 35 Weigh the samples



Record any irregularities that occurred during saturation (e.g. swelling of clayey soils, changes in soil structure, accidental loss of soil material).

Water content measurements at pF 0 are relatively inaccurate:

- It is difficult to transfer the saturated sample to a balance without changing water content, especially with sandy samples.
- The middle of the soil sample is used as the reference level for zero pressure, but the free water level ($h = 0$) is in fact 1 cm below the top of the sample ring. The moisture tension thus ranges from +1 cm at the bottom of the sample, to -4 cm at the top of the sample. Note that at lower pressures this difference due to sample size becomes less important.



Figure 36: Press to ensure soil-sand contact

5.11 Place the ring on the sandbox. Press the ring slightly, to improve soil - sand contact. (Fig. 36).



Figure 37: Pressure of -2.5 cm head (pF 0,4)

5.12 Slide the suction regulator so that a pressure of -2.5 cm head is applied to the centre of the samples. (This level is equal to the level of the sand when standard 5 cm sample rings are used.)

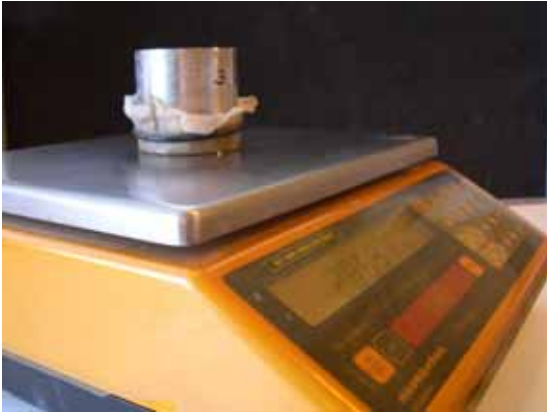

Figure 38: Check Sample reached equilibrium



Figure 39: Clean & smooth surface with sponge



Figure 40: Replace samples

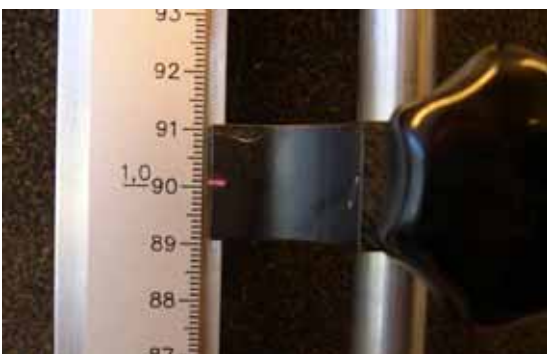

Figure 41: Next standard potential increment

- 5.13 Leave the sample to equilibrate, (with the lid on the box to stop evaporation). This will take a few days for sandy soil, and up to a week for clayey soils.
- 5.14 Gently remove the samples and weigh them. (Fig. 38).
- 5.15 To check equilibrium, place the sample on the suction table at exact the same place (take care that the contact between sand and sample is restored) and weigh the sample again the next day. In case of equilibrium with the created tension, the difference in water content will not exceed 0.002 in volume fraction.
- 5.16 If equilibrium between soil moisture content and pressure has been established, record the weight of the sample. (Wipe sand grains and water drops from underneath the sample before weighing - for calculation of soil water content Weight A, see Chapter 6).
- 5.17 Moisten the sand surface with a wet sponge. Don't remove the filter cloth -just clean and smoothen it at the same time to remove air bubbles and impressions. (Fig. 39).
- 5.18 Replace the soil samples on the sand at exactly the same position as they were previously. (Use the diagram made earlier). (Fig. 40).
- 5.19 Slide the suction regulator down to the next standard water potential increment, so that a greater suction is applied to the centre of the samples. (Eg: -10.0 cm water (pF1.0), -31.6 cm water (pF1.5), -63.1 cm water (pF1.8) and -100 cm water (pF2.0). (Fig. 41)



Figure 42: Wait for soil-water equilibrium

5.20 Wait for soil-water equilibrium (Eg. 2 to 3 days for sand and longer for clay). (Fig. 37).

5.21 Repeat steps 5.10 – 5.19 until weights have been recorded at each of the potential increments that you want to measure.



Always replace the samples on the sand before moving the suction regulator.

6 Table to be filled in as measurements are taken.

Sample number	Ring number	pF	Cm water column (potential in MPa)	Weight (g)					V = Volume of core ring =cm ³			
				Wet weight (sample, ring, cloth, elastic) A	Dry weight (sample, ring, cloth, elastic) B	Weight of ring, cloth, elastic C	Weight of soil water D = A - B	Weight of dry soil E = B - C	Gravim. water content W = D/E	Bulk density (g / cm ³) ρ _d = E/V	Volume Water content θ = W * ρ _d	
		0,0	1,0									
		0,4	2,5									
		1,0	10									
		1,5	31,6									
		1,8	63,1									
		2,0	100									

7 Troubleshooting

Problem	Possible causes	Solution(s)
Air in the tube between the supply bottle and the suction regulator is distorting the measurements.	1. There are air bubbles in the water.	1. Only use the water if it's calm. Let the supply bottle stand still for a while before using the water. De-aerate the tube.
	2. There is not enough sand above the drainage pipe inside the box.	2. Add more water-saturated sand. The sand level should be at least 5cm above the highest point of the drainage pipe.
	3. Air is entering via the side walls of the box because sand wasn't pressed against the walls properly during the setting-up stage, or vibration has broken the seal.	3. Remove the sand from the sandbox and begin the setting up process again at step 9. Ensure that the sand is completely saturated, and that it is forced into the corners, and against the walls, of the box.
	4. There is a leaking cock/tap.	4. Order a new cock/tap.

8 Maintenance of suction tables

To prevent pores from becoming clogged by algae or bacterial growth, the suction tables should be flushed once or twice a year with a solution of hot water, and possibly with acetic acid to prevent calcium deposits.

The suction tables must be flushed until only clean water emerges. A copper washer is placed in the suction regulator to prevent algae growth. Diluted copper sulphate may be added to the water in the supply bottle for the same reason. Rather than flushing the suction table, it is also an option to change the sand or the sand and totally refill the box.

It is recommended to regularly wash the filter cloth that covers the sandbox.

Whenever the sand suction table is not in use, sand should be immersed in water and a suction level of 100 hPa (pF 2) should be retained.

Appendix 1: General Information

The pF-curves plotted below will be used to illustrate the soil physical characteristics that can be deduced from pF-curves. The example soil contains three different soil horizons (each of which has a known pF-Curve). These curves are referred to in Table 3.

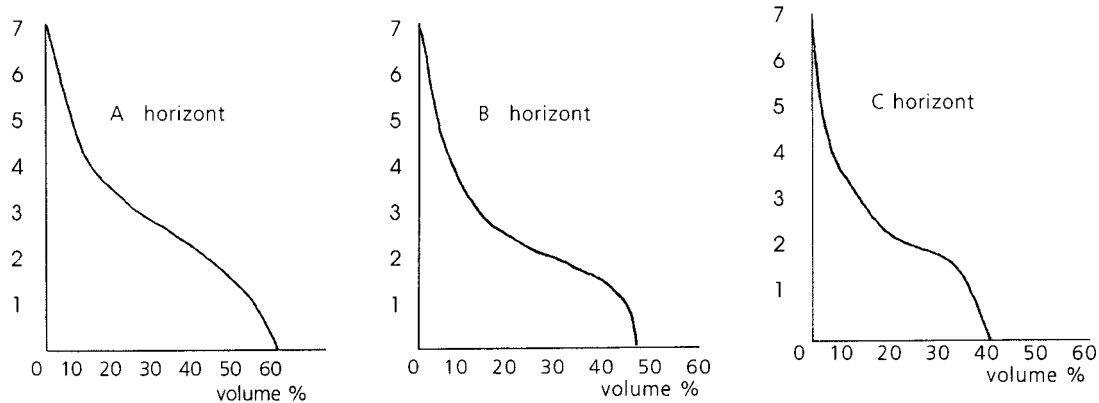

Table 3: Determining soil characteristics from pF-Curves

Physical Characteristic	Definition and how to determine
Moisture content	Volume fraction of water filled pores at a certain matric potential. For example, at a matric potential of 1000 hPa (1 bar, pF 3.0), the A horizon has a volumetric moisture content of 20 %.
Field capacity (FC)	Moisture content at pF 2 The A horizon has a moisture content of 35 % at FC and the C horizon 24 %.
Permanent wilting point (PWP)	Moisture content at pF 4.2 The A horizon has a moisture content of 8 % at PWP and the C horizon 4 %.
Porosity	In a sandy soil, all pores are filled with water at saturation (pF 0), and empty when oven-dry (pF 7). Therefore, the volume percentage between pF 0 and pF 7 is equal to the porosity in a sandy soil. In a clay soil porosity, or total pore volume, depends upon moisture content, due to swelling and shrinking. Therefore, for clay soil porosity cannot be determined from the pF -curve. The example soil is a loamy sand soil, and allows estimating porosity: At saturation, the A horizon has a volumetric moisture content of 50 %, when the soil is oven dry the moisture content is 0 %, therefore, 50 % of the soil volume is pore space, filled with water and air, and porosity is 50 %.

Volume fraction solid matter	<p>Total volume fraction minus porosity.</p> <p>Since porosity of the A horizon is 50 %, the volume fraction of pores is 0.5 and volume fraction of solid matter in the A horizon is $1 - 0.5 = 0.5$</p>
Aeration status	<p>Volume of available air: porosity minus moisture content. Depending on crop type, a certain ratio between water and air supply is required for optimal crop growth.</p> <p>In the example soil, (A horizon) at a moisture potential of 1000 hPa (pF 3), moisture content is 20%, total pore space is 50 %, so the volume of available air is 30 %.</p>
Pore size distribution	<p>Shape of pF curve: Pores of similar size will be emptied at the same matric potential. The more homogenous the pore size distribution, the faster the drop in soil moisture content upon a small decrease in matric potential, and the flatter the slope of the pF curve. The steeper the slope, the more gradual the emptying of soil pores, the more heterogeneous the pore size distribution.</p> <p>In general, a heterogeneous pore size distribution is preferable for agricultural applications, since these soils have a higher water holding capacity.</p> <p>The example soil illustrates the effect of organic matter presence and biological activity in the A horizon. In the A horizon, the slope of the pF-curve is more gradual than in the C horizon, meaning that pores are emptied more gradually in the A horizon, corresponding to a heterogeneous pore size distribution. The C horizon contains a relatively large amount of pores of similar size, which are all drained around a matric potential of - 100 hPa (pF 2). A slight increase in the suction will lead to a change in moisture content of almost 10 %.</p>
Capillary conductivity	<p>The rate of capillary conductivity depends upon the amount and size of water filled pores involved in water flow. This depends upon the moisture potential of the soil.</p> <p>A decrease of the water potential (an increase in suction level) corresponds with a decrease in moisture content. Because water is forced to flow through narrow pores with a high friction, this consequently leads to a reduction in the capillary motion.</p> <p>Permeability rate depends on the distribution and amount of macro-pores.</p>

Storage capacity	<p>Storage capacity of a soil at a specific ground water level corresponds to the air volume present. Storage capability is expressed in mm water per decimetre of soil (1 mm water per 10 cm³ volume percent).</p> <p>For the example soil, the storage capacity of the C horizon at a moisture tension of 100 hPa (pF₂) is calculated as total pore space (40 %) - moisture content (25 %) = volume of air (15 %). A volumetric air content of 15 % corresponds to a storage capacity of 15 mm of water per decimetre of C horizon.</p>
Plant available soil water	<p>The amount of water between FC and PWP in volume percentage. This value should be used with caution. First, plants will start wilting with subsequent yield losses well before the permanent wilting point. Secondly, plant available soil water is replenished by capillary rise, rainfall and irrigation water.</p> <p>Eg: A fine sandy soil, rich in loam has a rooting depth of about 40 cm.</p> <ul style="list-style-type: none"> • The A horizon has a depth of 20 cm. • The B horizon has a depth of 30 cm. <p>Calculation of the amount of plant available soil water:</p> <p>At field capacity, pF_{2.0}, the A horizon will contain 35 volume % of water. At the permanent wilting point, pF_{4.2}, the A horizon will contain 8 volume % of water. As 1 volume % corresponds to 1 mm water per 10 cm of soil, the amount of available soil water in the A horizon is calculated as the volume % of water multiplied with the rooted depth of the soil horizon:</p> <p>A horizon: 35 - 8 = 27 volume % water x 20 cm soil depth = 54 mm</p> <p>For the B horizon the calculation is similar. Notice that rooting depth is 40 cm, so roots will be present only in the upper 20 cm of the B horizon. At field capacity 27 % of water will be available, at the permanent wilting point only 6%.</p> <p>B horizon: 27 - 6 = 21 volume % of water * 20 cm rooted soil depth = 42 mm water</p> <p>In total, 54 + 42 = 96 mm of water is available to plant growth in this particular soil.</p>

Appendix 2: Description of different pF-sets

To determine the soil moisture retention characteristic, the desired pF-set(s) is/are required. A balance with an accuracy of 0.01g, and a ventilated electrical drying oven (105 °C), are also necessary. Eijkelkamp supplies the following:

A universal drying-oven with temperature range 30 -220 °C, 220 V- 50 Hz.

A Sandbox for pF determination (pF0 -2.0). The Standard set for about 40 samples includes:

- Sandbox
- Containers with sand, particle size \pm 73 mm, 12.5 kg each
- Filter cloth, 140 - 150 mm
- Set of 65 o-rings, diameter 49 mm: suitable for 5 cm diameter core rings

A Sand / kaolin box for pF determination (pF2.0 - 2.7). The Standard set for about 40 samples includes:

- Sand / kaolin box
- Vacuum pump and automatic suction level control system, 220 V
- Containers with synthetic sand, particle size \pm 73 mm, 12.5 kg each
- Filter cloth, 140 - 150 mm
- Kaolin clay, container 2.5 kg
- Set of 65 o-rings for 5 cm diameter core rings

Pressure Membrane Apparatus (pF3.0 – 4.2). The standard set for about 15 samples includes:

- Pressure membrane extractor
- Cellophane membrane
- Soil sample retaining rings
- Filter cloth 140 - 150 mm
- Compressor 20 bar
- Air filter with support and hose

Appendix 3: Conversion factors

100 hPa = 100 cm pressure head
= 100 cm water column
= 0.1 bar
= 0.01 Pa
= 0.01 N/m²
= 1.45 PSI
= pF (¹⁰log100) = 2.0

pF value	Matric Potential in hPa	Pressure in bar
0	1	- 0.001
0.4	2.5	- 0.0025
1.0	10	- 0.01
1.5	31.6	- 0.0316
1.8	63.1	- 0.0631
2.0	100	- 0.1
2.3	200	- 0.2
2.7	500	- 0.5

Appendix 4: Soil sampling

To determine the moisture retention characteristic or the pF-curve of a specific soil, *undisturbed* core samples must be collected. This is because of the major influences of both pore size distribution and soil structure on moisture retention, especially at the high matrix potentials of the operating range of suction tables.

There is no explicit prescription in literature for recommended sample sizes. Optimal sizes for core rings are determined by the size of structural elements in the soil. To obtain representative data, sample sizes should be large with respect to the size of soil aggregates, cracks, root channels or animal holes. From a practical point of view, sample diameters should not be too large as not to reduce the amount of simultaneously analysable samples, and sample height should be constrained to several centimeters; so that equilibrium conditions are reached in a reasonable period of time.

According to the Dutch NEN 5787 standard, samples with a volume between 100 and 300 cm³ are usually used for the suction tables, while samples with a height of more than 5 cm are discouraged, because the time needed to establish equilibrium will be long, and the accuracy of determination of pF-values near saturation will be low. In the procedures for soil analyses of the International Soil Reference and Information Centre (ISRIC), sample rings with a diameter of 5 cm and a volume of 100 cm³ are recommended, while in other publications heights of 2 or 3 cm are preferred.

Eijkelkamp Agrisearch Equipment recommends the use of a 100 cm³ volume core ring, with an inner diameter of 50 mm (outer diameter 53 mm) and a height of 51 mm.

When pressing the core rings into the soil, care should be taken not to disturb the original setting of the soil and to completely fill the ring. Sampling conditions are best when the soil is approximately at field capacity. Ring holders may be used to facilitate insertion, especially in the subsoil. After insertion to the desired depth, the rings are carefully dug out (e.g. using the spatula provided with the Eijkelkamp sample ring set), at some centimeters below the ring itself. The surplus of soil is reduced to a few millimeters, trimming it carefully with a fine iron saw, and the caps are placed on the ring for protection and to minimise evaporation losses. The remaining surplus of soil will protect the sample during transport and will be removed in the laboratory, prior to analysis. Transport the core rings in a protective case.

Since soil structure and pore size distribution have significant influence on soil water retention, several replicate samples are needed to obtain a representative pF-value. Depending on natural variability of the study area, three to six replicate samples per unit are advised.

In case the samples cannot be analysed on short notice, store the samples in a refrigerator to reduce microbial activity which might cause non-representative changes in soil structure.



Do not freeze the samples because soil structure will be influenced.

References and literature

Klute, A. Water Retention: Laboratory Methods. IN: Methods of Soil Analysis. Part 1. Physical and Mineralogical Methods. 1986.

Koorevaar, P., G. Menelik and C. Dirksen. Elements of Soil Physics Developments in Soil Science 13 1983

Reeve, M.J. and A.D. Carter. Water Release Characteristic. IN: Soil Analysis. Physical Methods. K.A. Smith and C.E. Mullins (eds.) 1991.

Van Reeuwijk, L.P. (ed.) Procedures for soil analysis. 1995. ISRIC Wageningen.

Stakman, W.P., G.A.Valk and G.G. van der Harst. Determination of soil moisture retention curves I. 1969. ICW Wageningen.

Stolte (ed.) Manual for soil physical measurements. Version 3. Technical Document 37. SC-DLO. 1997.

Topp, G.C. and W. Zebchuk. The determination of soil water desorption curves for soil cores. 1979. Canadian Journal of Soil Science 59: 19-26.